



RESILIENT SEATED GATE VALVES

KENNEDY SERIES 31

to EN/ISO Standards

Kennedy Gate Valves with their unique features have been used in the water and fire protection industries since 1877. Our Series 31 Gate valves conform to EN/ ISO standards and have been designed to maintain the high quality and integrity of existing designs but incorporates many superior features like unique integral wedge nut and a maintenance free triple stem seal design. Series 31 Gate Valves are made in Cast Ductile Iron body with wedges totally encapsulated in Rubber, offering bubble tight shut off. Valves are designed with smooth unobstructed flow paths and are free of pockets, cavities and depressions in the seat area.

Valves are suitable for water and neutral liquids to a maximum temperature of 70°C.



General Specifications

Design & Test Standards: EN1074-1&2, IS 14846

Type: Resilient Seated Ductile Iron Gate Valves

Non Rising Stem, Meets EN Standards

Sizes : DN 50 - DN 400

Working Pressure: 16 Bar

Models

311: Face to Face ISO 5752 Series 3

314: Face to Face ISO 5752 Series 14

315: Face to Face ISO 5752 Series 15

Flanges

EN 1092-2, IS 1538 PN16

Face to Face

EN 558 & ISO 5752 standards

Test Pressure

Pressure Testing to EN 1074 - 1&2 and EN 12266-1&2

Seat Test : 1.1 x PN (18 Bar)

Body Test :1.5 x PN (24 Bar)

Coating

Fusion bonded non-toxic epoxy coating NSF 61

Minimum 300 micron

Bolts are seated with hot melt

Options

Stem Cap, Hand wheel, T-Key

Alternative flange drillings

ISO Top Flange

Material Specifications (Trim 101)

Body & Bonnet	: Ductile Iron –ENJS 1050	O Rings	: EPDM
Wedge	: EPDM encapsulated Ductile Iron	Thrust Collar	: Copper Alloy, (Ph.Bronze)
Stem	: Stainless Steel 316	Bonnet Gasket	: EPDM
Wedge Nut	: Copper Alloy, (Ph.Bronze)	Stem Bearing	: Polyamide Polymer
Bolt & Nuts	: Stainless Steel A4	Coating	: Fusion Bonded Epoxy 300 µm

EPDM Rubber available with NSF 61 approval suitable for potable water.
Please check with us for other material combinations.

DIMENSIONS AND PART LIST – RS Gate Valve Series 31

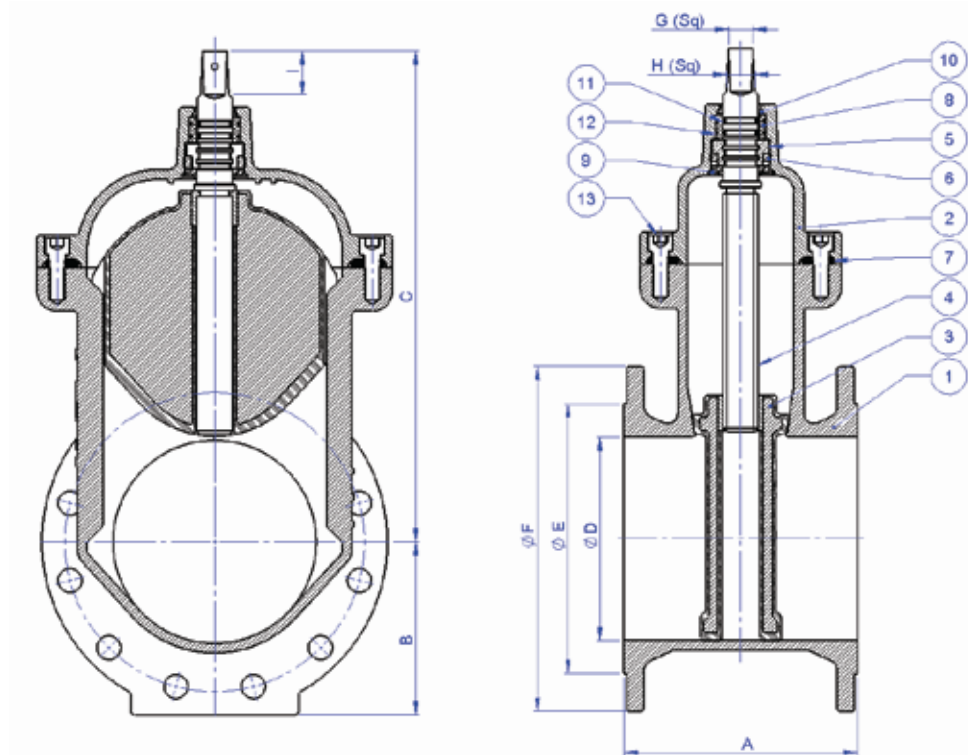

COMPONENTS

- | | | | |
|-----------|----------------------|-----------------|-----------------|
| 1. Body | 5. Thrust Collar | 9. Seal | 13. Bonnet Bolt |
| 2. Bonnet | 6. Thrust Collar Nut | 10. End Seal | |
| 3. Wedge | 7. Gasket | 11. O Ring Stem | |
| 4. Stem | 8. Bush | 12. O Ring Bush | |

DIMENSIONS (mm) for PN 16

Size DN	A			ØB	ØC	ØD	E	F	G (Sq)	H (Sq)	I	Weight Approx. (Kg.)		
	Model 314	Model 311	Model 315									Model 314	Model 311	Model 315
50	150	178	250	82.5	217	50	99	165	13.5	16	26.5	12	12	13
65	170	190	270	92.5	234	65	118	185	17	20	34	15	15	16
80	180	203	280	100	261	80	132	200	17	20	34	16	17	18
100	190	229	300	110	299	100	156	220	19	22	38	20	21	23
125	200	254	325	125	355	125	184	250	19	22	38	33	35	36
150	210	267	350	142.5	393	150	211	285	19	22	38	40	42	45
200	230	292	400	170	483	200	266	340	24	28	43	60	63	68
250	250	330	450	200	568	250	319	400	27	31	47	84	89	96
300	270	356	500	227.5	686	300	370	455	27	31	47	148	157	173
350	290			260	762	350	429	520	32	37	55	205		
400	310			290	842	400	480	580	32	37	55	254		

Kennedy and McWane Services are divisions of McWane Inc. USA
 The specifications and material grades shown are subject to revision without notice based on our product improvement programme